

Fiber Optic Isolator—Photologic® Sensor

OPI1290 Series



Features:

- Opaque plastic housings
- High noise immunity
- Visible Red LED with Phototransistor Output
- 0.05" (1.27 mm) lead spacing
- Data Transfer through plastic fiber optic cable
- Isolation voltage 15 KV (OPI1290-032), Longer versions higher

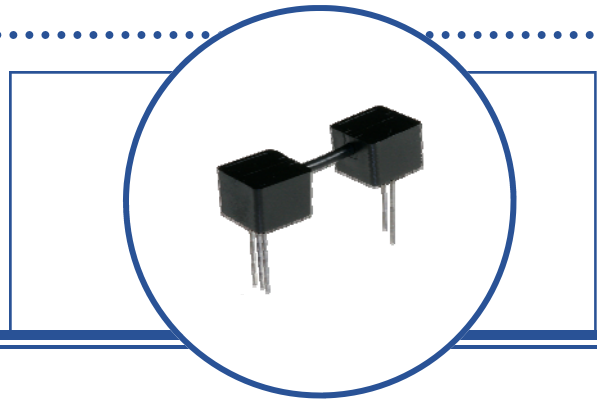

Description:

Each **OPI1290** consists of a visible Red LED and a Photologic® Totem-Pole output sensor, which are housed in separate opaque molded plastic housings and coupled by plastic fiber optic cable. The heavy-duty opaque housing shields the optical signal from dust, making this series of devices ideal for dust contaminated environments.

The **OPI1290** series are designed for applications that require high voltage isolation between input and output or signal communication over short distances. Depending on the length of the fiber optic cable, the emitter does not have to be optically in-line with the sensor. The isolation voltage is greater than 10 K volts per inch (Isolation distance between components) for all versions of the **OPI1290**.

Custom electrical, wire and cabling and connectors are available. Contact your local representative or OPTEK for more information.

Applications:

- Requiring High Voltage isolation between input and output
- Electrical isolation in dirty environments
- Industrial equipment
- Medical equipment
- Office equipment

Ordering Information				
Part Number	Isolation Distance ±2mm	Device Length ±2mm	LED Peak Wavelength	Lead Length
OPI1290-018	0.86" [22 mm]	1.26" [32.0 mm]	645 nm	0.45" [11.4 mm]
OPI1290-026	1.18" [30 mm]	1.57" [40.0 mm]		
OPI1290-032	1.42" [36 mm]	1.80" [45.8 mm]		
OPI1290-040	1.73" [44 mm]	2.12" [53.8 mm]		
OPI1290-066	2.76" [70 mm]	3.15" [80.0 mm]		
OPI1290-080	3.31" [84 mm]	3.69" [93.8 mm]		

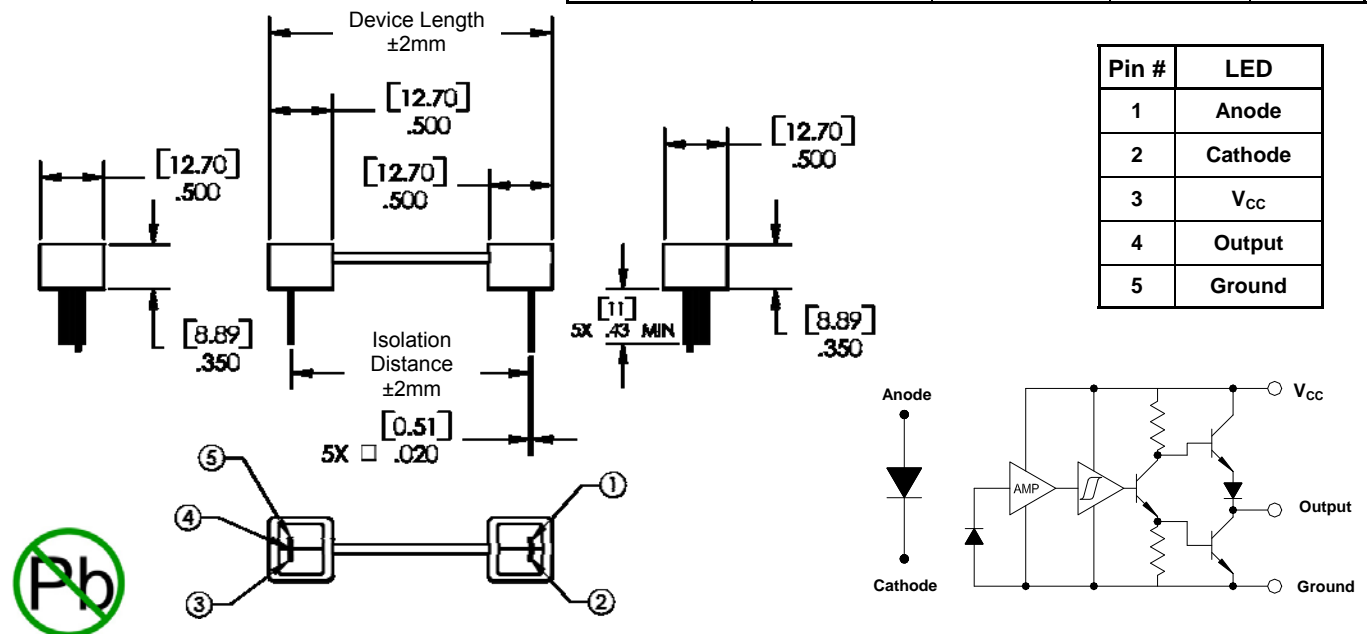

RoHS

OPTEK reserves the right to make changes at any time in order to improve design and to supply the best product possible.

Absolute Maximum Ratings ($T_A=25^\circ\text{C}$ unless otherwise noted)

Storage Temperature Range (note 3)	-40° C to +80° C
Operating Temperature Range (note 3)	-20° C to +75° C
Lead Soldering Temperature [1/16 inch (1.6 mm) from case for 5 seconds with soldering iron]	260° C ⁽¹⁾
Power Dissipation ⁽²⁾	100 mW

Electrical Characteristics ($T_A = 25^\circ\text{C}$ unless otherwise noted)

SYMBOL	PARAMETER	MIN	TYP	MAX	UNITS	TEST CONDITIONS
--------	-----------	-----	-----	-----	-------	-----------------

LED (See OP240 for additional information)

V_F	On-State Collector Current	1.2	-	2.3	V	$I_F = 20\text{ mA}$
I_R	Collector-Dark Current	-	-	80	μA	$V_R = 3.0\text{ V}$

Photologic® Sensor (See OP550 for additional information)

SYMBOL	PARAMETER	MIN	TYP	MAX	UNITS	TEST CONDITIONS
V_{CC}	Operating Supply Voltage	4.5	-	16	V	-
	Peak-to-Peak V_{CC} Ripple Necessary to Cause False Triggering of Output	-	-	2	V	$V_{CC} = 5\text{ V DC}$, $f = \text{DC to } 50\text{ MHz}$
I_{CC}	Supply Current ⁽⁴⁾	-	8	15	mA	$E_E = 0\text{ or } 3\text{ mW/cm}^2$, $V_{CC} = 5.5\text{ V}$
$E_{eT(+)}$	Positive-Going Threshold Irradiance ⁽²⁾	.25	-	2.4	mW/cm^2	$V_{CC} = 5\text{ V}$, $T_A = 25^\circ\text{ C}$
$E_{eT(+)}/E_{eT(-)}$	Hysteresis Ratio	1.50	2	2.5	-	-
V_{OH}	Operating Supply Voltage	$V_{CC} - 2.1$	-	-	V	$I_{OH} = -1\ \mu\text{A}$, $E_E = 1\text{ mW/cm}^2$
V_{OL}	Low Level Output Voltage	-	0.25	0.4	V	$V_{CC} = 4.5\text{ V}$, $I_{OL} = 12.8\text{ mA}$, $E_E = 0$
I_{OS}	Short Circuit Output Current	-20	-55	-100	mA	$V_{CC} = 5.5\text{ V}$, Output = GND, $E_E = 3\text{ mW/cm}^2$
I_{OH}	High Level Output Current ⁽²⁾	-	1	100	μA	$V_{CC} = 4.5\text{ V}$, $V_{OH} = 30\text{ V}$, $E_E = 3\text{ mW/cm}^2$
T_R & T_F	Output Rise & Fall Time	-	25	70	ns	$V_{CC} = 5\text{ V}$, $T_A = 25^\circ\text{ C}$, $E_E = 0\text{ or } 3\text{ mW/cm}^2$, $f = 10\text{ kHz}$, DC = 50% $R_L = 8\text{ TTL loads}$
$tp_{E_{eT}(+)}$	Propagation Delay Positive-Going	-	2.5	5.0	μs	$V_{CC} = 5\text{ V}$, $T_A = 25^\circ\text{ C}$, $E_E = 0\text{ or } 3\text{ mW/cm}^2$, $R_L = 8\text{ TTL loads}$, $f = 10\text{ kHz}$, DC = 50%
$tp_{E_{eT}(-)}$	Propagation Delay Negative-Going	-	2.5	5.0	μs	$V_{CC} = 5\text{ V}$, $T_A = 25^\circ\text{ C}$, $E_E = 0\text{ or } 3\text{ mW/cm}^2$, $R_L = 360\ \Omega$, $f = 10\text{ kHz}$, DC = 50%
t_{PLH} , T_{PHL}	Propagation Delay (Low-High/High-Low)	-	5.0	-	μs	DC = 50%, $R_L = 10\text{ TTL Loads}$

Notes:

- (1) Derate linearly 2.5 mW/° C above 25° C for all devices in the OPL550, OPL551, OPL560, OPL561, OPL562 and OPL563 series.
- (2) Irradiance measurements are made with $\lambda_i = 935\text{ nm}$.
- (3) Storage and Operating temperature values are based on the plastic optical interface temperature ratings. Please reference UL1577 and UL file AVLVZ.E89328

OPTEK reserves the right to make changes at any time in order to improve design and to supply the best product possible.