

Designing a "Wide-Gap Optical Switch" using an OP293/OP298 (plastic TO-46 equivalent) LED and OP593/OP598 (plastic TO-18 equivalent) phototransistor.

Introduction

The application described here is commonly referred to as "object presence" sensing. It is the use of a single pair of active components, (LED and sensor) to sense the interruption of an optical path by an "opaque" object. This type of beam interrupt switch is applied in industrial controls and computer peripherals to signal:

- seating of tape cartridge
- door position on disk drives
- obstructions of document paths
- conveyor feed rates

Compared to many encoder type switches this application is simpler from the standpoint of speed and resolution requirements. It can, however, have its own set of challenging design considerations depending on the length of the optical path and the constraints of performance, environment, and cost. This example is intended to illustrate the major design variables of a relatively long optical path switch and how the information of the component data sheet can be used to choose and apply the parts.

"The Gap"

Many off-the-shelf optical components are easily applied in short-gap switches because their inherent coupling characteristics produce a useable signal over a wide range of drive and mounting conditions. As the gap widens, the coupling of light between the emitter and sensor drops off rapidly and an appreciation of techniques for optimizing performance is critical. The coupling curve from the OP293/OP298 data sheet illustrates the relationship between signal strength and gap width.

Figure 1 - Coupling Characteristics of OP293/OP298 and OP593/OP598 vs. Lens Tip Separation

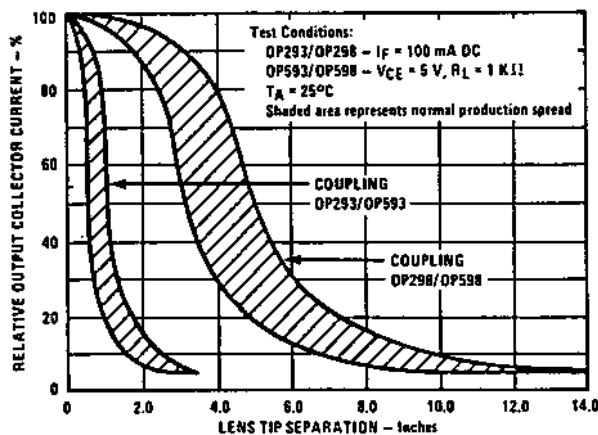

The more rapid decrease in coupling vs. distance of the OP293/OP593 pair is due to the differences in package lenses which produce a wider beam angle.

Other package types have similar coupling curves, most decreasing with distance more rapidly than this family of parts. The OP298/OP598 pair will be used for the example because of the superior coupling at longer distances.

All the performance optimizing techniques are tied to the clear definition of system constraints and minimizing both electrical and mechanical tolerances.

"Black Box"

The "system" level of the application should be as clearly defined as possible to enable definition of mechanical tolerances, ambient conditions, and output limits.

The "Black Box" is defined by a package outline, an electrical schematic and some environmental conditions.

Figures 2, 3 and 4 completely define the requirements of the system.

Figure 2 - Package Outline

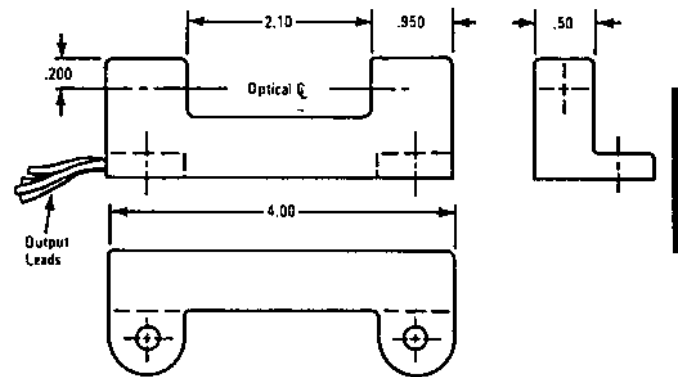

Figure 3 - Schematic/Drive

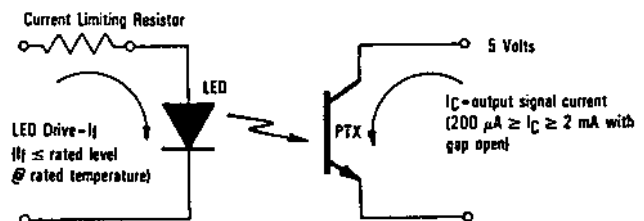

Figure 4 - Operating Conditions

Operating Temperature Range	(0°C to 55°C)
Voltage Supply Tolerance	(± 10%)
Required Operating Life	50K Hours

Other ambient conditions: To simplify the example, assume a relatively clean environment and one in which ambient light conditions will not produce errors in the output signal. Both of these conditions can be addressed with filters over the devices and additional performance tolerances.

Basic Guidelines

To ensure that the system will work over the full range of operating conditions and will also be manufacturable, some trade-offs and tolerances must be introduced. As with every other circuit, the performance variations versus temperature, life, and supply voltage are considered. The optically coupled circuit has the additional tolerance associated with the beam alignment of the LED and sensor.

Oftentimes the single largest tolerance of the optical (infrared) switch design is associated with the degradation of LED power output over time. By nature, the efficiency of either GaAs or GaAlAs LEDs decreases with use and is directly proportional to both drive current and operating temperature. Since the "Black Box" definition fixed the temperature range, the degradation tolerance can be minimized only by minimizing the drive level. The other system components can be considered to have virtually no performance change with time in a clean environment.

The Coupled Pair

The basic tasks of the switch design are selection of a component pair which will meet the black box conditions and encasing the pair in a manner which will optimize long-term performance. The packaging scheme will define the exact lens-to-lens spacing, the beam alignment accuracy, and the components' heat sinking conditions that dictate power dissipation.

Figure 5 shows a section view of the switch with the components mounted on a printed circuit board and held in alignment by cylindrical plastic cavities. The lenses of the parts are recessed in the cavities. This increase in the lens-to-lens spacing will decrease the coupling slightly; but, the aperturing effect of the cylinders will limit the beam angle of the parts and help reduce reflections or the sensing of light from other sources which could give erroneous signals. Additional stray light protection could be provided if required by making changes in interfering surfaces or by aperturing.

Figure 5 - Mechanical Design

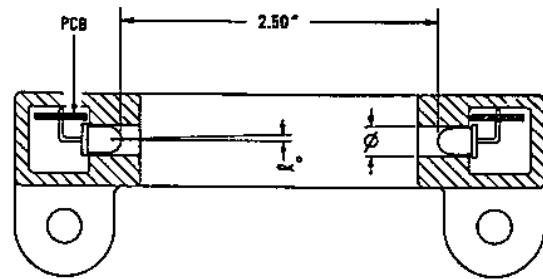

The mechanical alignment of the components will depend primarily on three tolerances, (1) the diameter of the LED and sensor package, (2) the diameter of the cylindrical cavities, and (3) the straightness or flatness of the housing which maintains the beam axis.

Figure 6 - Package Tolerance

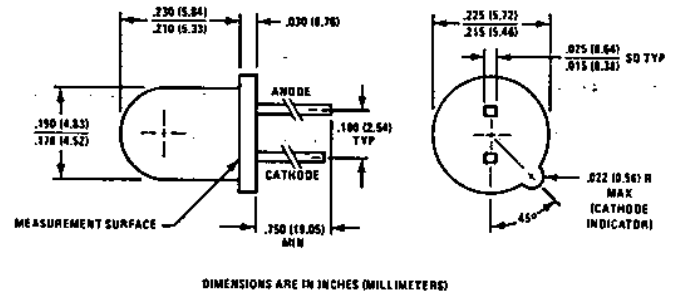

From the data sheet of the OP298 and OP598 (figure 6), the discrete package tolerance is ±.006 inches for both LED and sensor. Figure 7 shows the possible beam misalignment attributable to the worst case dimensions of the component and housing if the cavity is made to fit the largest possible package. It is assumed the cylindrical cavity can be molded to a tolerance of ±.0005 inches.

Figure 7 - Package Misalignment

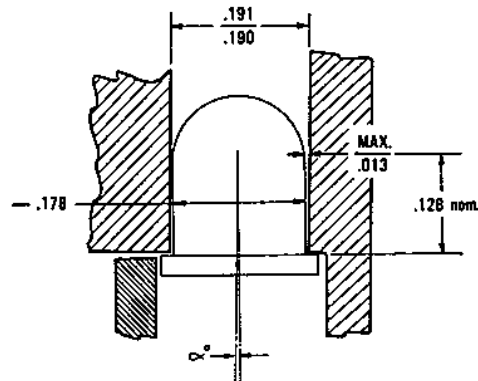

In practice, an improvement can be made on the fit of the components by introducing details in the cavities which make use of the plastic's flexibility. Even with glass filled material, the addition of small ribs along the cavity walls will hold the smaller diameter components in better alignment and can compress to allow a press fit of the larger parts.

Figure 8 - Tightening Ribs

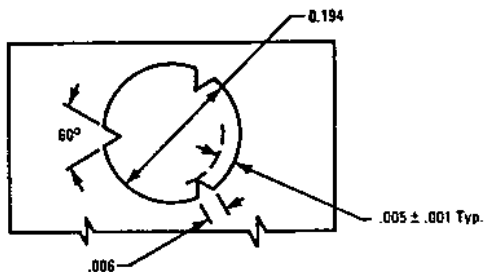

The tightening ribs shown in figure 8, reduce the diameter mismatch to $(.184 - .178) = .006$ max. reducing the optical axis displacement to:

$$\tan^{-1} \frac{.006}{.128} \approx 2.9^\circ$$

The misalignment associated with curvature of the housing will depend on the method of construction; however, for a molded plastic housing of this size it would be fair to assume a flatness of .005 inch. Over the optical path of (2.50 inches) this warp should not contribute more than $\approx \tan^{-1} \frac{.005}{2.50} \approx .11^\circ$ shift off axis. With this addition to the shift from the cavity tolerance, it can be assumed the LED or sensor could be misaligned as much as four degrees (3°).

Power Requirements

The ratings of the OP598 are given in terms of milliamps (mA) of collector current when irradiated by a tungsten source of 5 mW/cm² and supply voltage of 5 volts. The data sheet characteristics, together with the "black box" constraints, enable calculation of the power required from the LED.

The tolerances to be considered for the transistor's power requirements are associated with collector current changes with temperature and optical axis alignment.

The shift in spectral response of the transistor and spectral emission of the LED over temperature are relatively minor tolerances here but may need to be considered in designs with broader temperature ranges.

The data sheet curve for normalized collector current vs. temperature (figure 9), indicates an increase of one percent per degree Celsius, in a pulsed mode. The low current requirements of this design will not contribute enough heating to warrant adjustments to this curve. However, in a conservative design, this temperature characteristic should not be used as a factor that completely

compensates for the opposite temperature effect of the LED. The temperature sensitivity is dependent on the transistor's electrical gain and can vary significantly. The curve can be used as a worst-case tolerance, (25%) at the low temperature of this design.

Figure 9 - Normalized Collector Current vs. Ambient Temperature

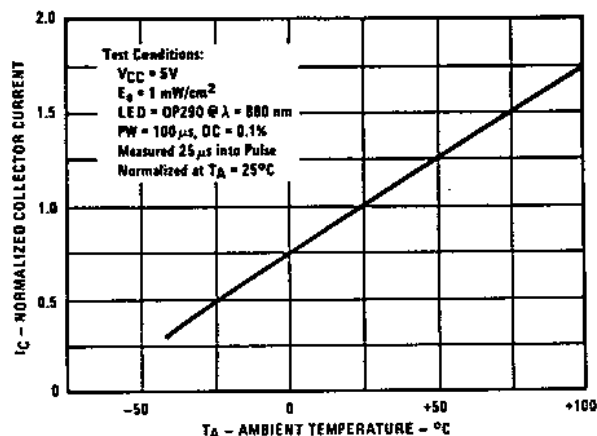

The worst-case optical axis misalignment has already been calculated to be four degrees (3°). Its effect can be estimated from the curve of normalized collector current vs. angular displacement, figure 10. The narrow beam of the OP598 makes the part more sensitive than the OP593 to misalignment (dropping $\approx 15\%$) but this does not outweigh the rated performance advantage of more than two to one.

In contrast to many hermetic devices, the molded optics of the OP598 is very consistent. The beam pattern graph, therefore, accurately represents performance and requires no additional tolerancing.

Figure 10 - Normalized Collector Current vs. Angular Displacement

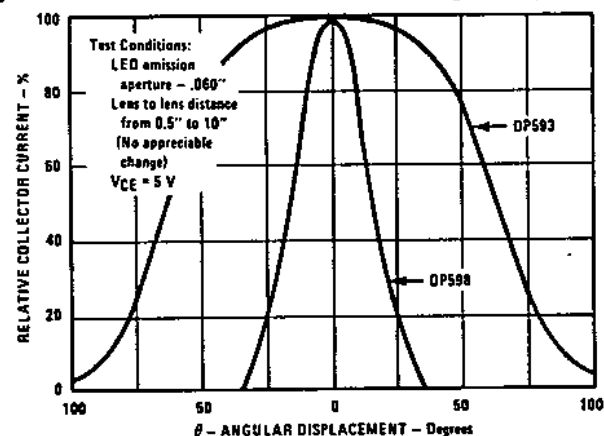

To find the basic radiant power requirement, the data sheet's tungsten test rating must be converted to one which reflects the transistor's sensitivity to the GaAlAs emission of the OP298. Figure 11 shows how the collector current varies with power intensity and the type of source used.

Figure 11 - OP593/OP598 IC vs. Irradiance

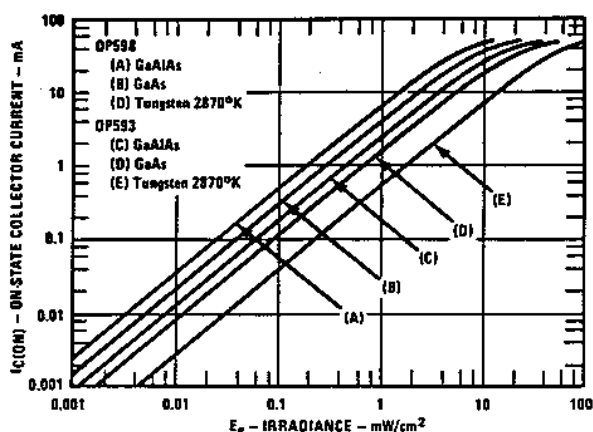

Curves A, B and D represent the typical response of the OP598 to GaAlAs, GaAs and tungsten sources respectively.

Curves C, D and E show the OP593 collector current variation vs. power for each source.

The tungsten response curve of the OP598 (curve D), intersects the irradiance level of 5 mW/cm² at a current level of between seven and eight milliamps. This curve, therefore, reflects the minimum response of the highest range part (OP598A), or the middle of the rated response range for the OP598B. Direct calculation from the data of the curve, therefore, will insure performance estimates that are representative of a relatively wide distribution of the available components.

The parallel relationship of these curves can be translated into a convenient conversion ratio between each source. To determine the required power from each source for a given current level, the following conversions apply:

- tungsten to GaAs - divide by 1.50,
- tungsten to GaAlAs - divide by 2.55,
- GaAs to GaAlAs - divide by 1.70.

The power required to drive the transistor at the system's minimum limit of 200 μ A can now be calculated.

Applying the initial tolerances to the minimum limit

- 25% for temperature effects,
 - 15% for axis misalignment,
 - 10% power supply and measurement accuracies,
- establishes a new limit of (200 μ A) (1.75) = 350 μ A.

The curve of figure 11 for tungsten intersects 350 μ A at a radiant power level of about 250 μ W/cm².

Applying the conversion factor for GaAlAs, the power requirement is reduced to approximately 100 μ W/cm², which corresponds closely to the top curve of figure 11.

LED Drive

The ratings for the OP298 LED, like that of the OP598, establish performance limits at one set of conditions. The calculated power requirement of the transistor, together with the data sheet information, will be used to determine the minimum drive current for the OP298.

Tolerances we can apply to the LED without knowing how it will be operated, include:

- coupling vs. gap width,
- I_f vs. supply tolerance,
- axis misalignment,
- effects of ambient temperature.

The effects of power degradation with life and device heating require some knowledge of the operating current level.

Figure 12, Normalized Power vs. Distance, provides a conversion factor from the data sheet test distance to the applications gap distance. Since the curves reflect the spacing from the sensor to the LED flange, add the package length of .22 inches to the optical path length of 2.50 inches for conversion.

At the distance of 2.72 inches, the OP298 retains about 30% of its rated power intensity. The similarity in size between the data sheet aperture (.25") and the applications sensor diameter should make this conversion very accurate.

It is obvious from this figure why the narrow beam OP298 was chosen over the wider beam OP293. With the gap separation of this system, the OP293 retains only 2.5% of its rated power.

Figure 12 - Normalized Power vs. Distance

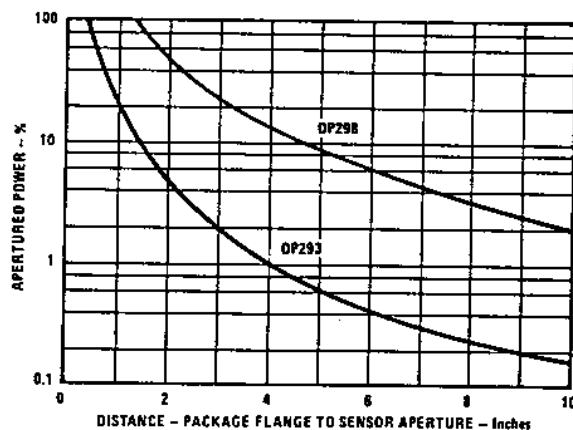

Assuming the LED current will be controlled by the five (5) volt supply and a limiting resistor, a notable tolerance results. Even with a quality resistor, the variation of the LED's forward voltage vs. current can produce a 15% drive current tolerance for a 10% voltage supply tolerance.

The axis misalignment from the mechanical design has been calculated to be 3° worst case. As with OP598, the effect on coupling will be in the range of 15%.

The system's ambient temperature range contributes a power tolerance of 25% at the upper limit of 55°C, as shown in figure 13.

Figure 13 - Normalized P_D and E_a(APT) vs. Ambient Temperature

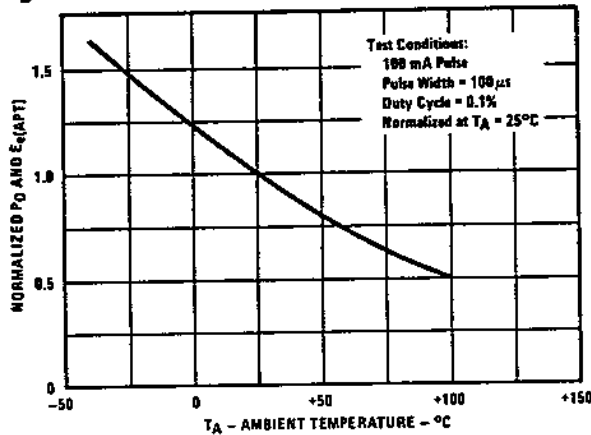

With these tolerance factors (15% axis misalignment; 15% power supply tolerance; and, 25% ambient temperature limit) and the power requirement of 100 μW/cm², the data sheet ratings can now be used.

Taking the initial estimate of power required by the sensor (100 μW/cm²), we can apply these first tolerances.

$$100 \mu\text{W}/\text{cm}^2 \times (85\% \times 85\% \times 75\%)^{-1} = 100 \mu\text{W}/\text{cm}^2 \times (1.85) = 185 \mu\text{W}/\text{cm}^2$$

This is the amount of power intensity which would be required at the data sheet's test distance of 1.425 inches. As was shown on figure 12, an IRLED at the designed gap would have only 30% of power measured at 1.425 inches. To convert for this 70% drop with distance, divide by 0.3. Thus
P min @ (2.75") = 617 μW/cm²

Referring to figure 14, it is evident from the curves of "Apertured Power Output vs. Time" that regardless of drive level, some decrease in available power must be accommodated as the unit is operated. To minimize this degradation effect, it will be important to select the lowest useable drive.

Figure 14 - Percent Change in Apertured Power Output vs. Time

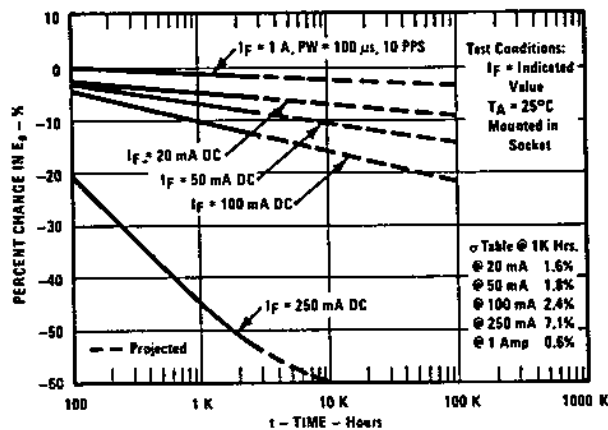

In another application with more demanding temperature requirements or less available heat sinking capacity, the upper limit of the LED drive may be dictated by the power dissipation rating. Note 1 of the data sheet shows, however, that the maximum continuous current can be applied up to 62.5°C with PC board heat sinking.

To get a rough idea of the design tolerance for degradation, follow the curve labeled 50 mA DC to the intersection at 50,000 hours (for approximately six years) of operation. The average unit will show a decrease in power of roughly 14% if operated at 25°C. The sigma (σ) table at the side of the curve indicates an additional 1.8% degradation for each standard deviation of distribution from this average. Each curve will run approximately parallel to the average curve through the 50,000 hour point.

Add three standard deviation percentages (3σ) to the 14% to estimate the degradation of the full distribution of components.
14% + (3) × (1.8) = 19.4%

To again take a conservative approach, assume the average temperature is 40°C rather than the 25°C illustrated by the curves of figure 14.

Characteristic data has shown that less degradation will occur from conditions of low current/high temperature than from high current/low temperature. Therefore, use the later condition as a model for the former and build in some safety factor. It should be kept in mind, however, that making degradation calculations with a higher current model is a very conservative approach, especially when working from the minimum ratings of the device.

From the thermal parameters of the OP298 data sheet, find the "normal" heat sinked thermal resistance of
R_{THJA} = 188°C/Watt.

With an average ambient temperature of 40°C, it is necessary to reflect a temperature rise of
40°C - 25°C = 15°C.

To raise the junction temperature by 15°C it is necessary to have a power dissipation increase of
15°C/188°C/watt ≈ .080 watts.

With an LED forward voltage of 1.6 volts, the increase in forward current associated with this power would be
80 mW/1.6 volts = 50 mA.

Therefore, use the 100 mA degradation curve to simulate the system if the average ambient temperature is 40°C and the drive current is 50 mA.

At the 50,000 hour point, the 100 mA curve shows an average degradation of 20% and each standard deviation produces an additional 2.4%.

For the full distribution of components, therefore, the maximum degradation should be $20\% + (3) (2.4\%) = 27.2\%$.

An additional temperature related power tolerance needs to be included in the calculation which will enable the conversion from the pulsed power rating at 25°C to a direct continuous current rating at the upper operating limit of 55°C.

Refer to the curve of figure 13, "Normalized Apertured Power vs. Temperature," and the thermal resistance rating to make this conversion.

Choosing again an operating point of 50 mA and noting that the worst-case forward voltage is 2.0 volts, the maximum power dissipation would be
 $P_d = (0.50) (2.0) = .100$ watts.

Using the thermal resistance of 188°C/watt, the temperature rise of the junction would be
 $T_{JA} = (.100) (188^\circ\text{C}) = 18.8^\circ\text{C}$.

It can be assumed that this junction temperature rise at an ambient temperature of 25°C and 100 mA DC would have essentially the same effect as an ambient rise of 18.8°C in the pulsed condition.

From the curve of figure 13, we can see the effect is to reduce the available power by approximately 18%.

Combination of all these tolerances allows calculation of a drive level which accommodates six years of continuous operation over the full temperature range. Adding these tolerances, 27.2 percent for degradation, and 18 percent for junction temperature rise indicates that at least 60 percent of the initial power will be available at "end of life."

The baseline power must first be calculated at the selected drive level of 50 mA using the minimum ratings of the data sheet.

IRLED is rated at 3.6 mW/cm² with a drive of 100 mA. Since the relationship between current and power is relatively linear in this range of operation, the power at 50 mA drive will be about one-half that at 100 mA, or 1.8 mW/cm².

Then applying the tolerances from heat and degradation
 $(1.8 \text{ mW/cm}^2) \times (60\%) = 1080 \text{ } \mu\text{W/cm}^2$

This is the minimum power the LED will provide over its full life and under worst-case conditions.

We can compare this figure with the power we calculated as the minimum required by the sensor, 617 $\mu\text{W/cm}^2$. Even with all the conservative design assumptions, the 50 mA drive level provides more than the necessary power.

The designer can, at this point, choose to further reduce the drive of the LED to enhance the operating life or maintain the margin for the sake of broadening the distribution of useable components. This can oftentimes be a cost consideration since price is usually directly proportional to power rating.

Conclusions

It should be kept in mind that throughout these calculations, most worst-case conditions were applied simultaneously, resulting in a very conservative design. The example shows that under certain conditions these components can be easily applied in switches which span several inches without straining the limits of performance.

The narrow beam components OP598/OP298 in particular are applicable in a wide range of configurations.

T. E. Eichenberger