

Photologic®

Historically, optoelectronic components such as phototransistors have been analog output devices. The application engineer had to design with an output current from the phototransistor generated by a given input bias circuit. The advent of the integrated circuits and microprocessors has required the electronics world to turn digital. The sophisticated electronics today communicate by logic levels of 1's or 0's. This means that the application engineer must now convert the analog light current of the phototransistor to a voltage level in order to communicate the sensing function to downstream processing electronics. This signal represents additional system cost in components and performance specification guard banding which can be reflected in the unit pricing of the optoelectronic component or assembly.

Photologic® discrete components, such as OPTEK's OPL800 family, utilize the best of the analog characteristics of the optoelectronic components and the signal processing capabilities of linear integrated circuits combining the two on one chip.

PHTOTOLOGIC DESCRIPTION

Photologic discrete components consist of an input photodiode, an amplifier (with gain), a high speed comparator (with or without hysteresis), and a power output device. The photologic sensor is used in many applications to convert input light to a logical high or low output. Its current applications include encoder, non-contact reflective object sensing, non-contact interruptive sensing, assembly line automation, machine safety, end of travel sensing, object sensing and paper sensing.

With the output of the optoelectronic component providing the application engineer with a logical level output, processing circuitry and performance specifications are more easily designed and integrated into their application thus reducing cost and passing savings on to the customer.

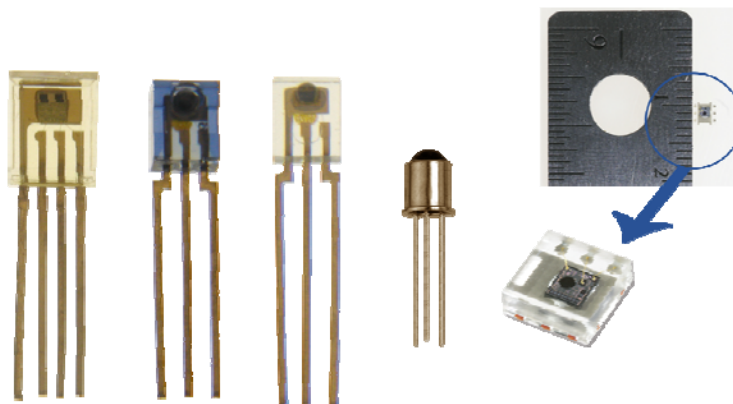

OPTEK reserves the right to make changes at any time in order to improve design and to supply the best product possible.

Photologic®

Totem-Pole Output Buffer

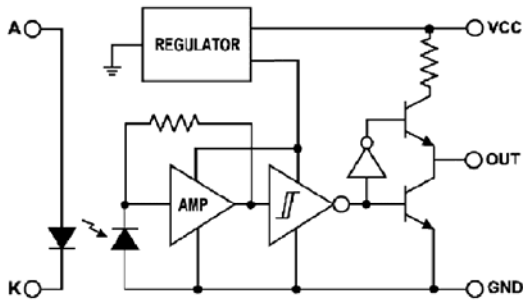

Totem-Pole Output Inverter

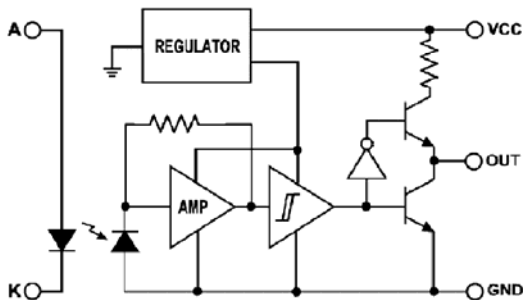

Open-Collector Output Buffer

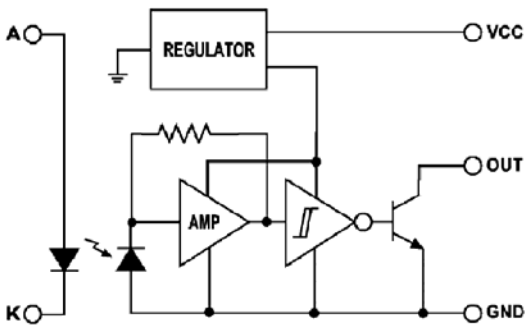

Open-Collector Output Inverter

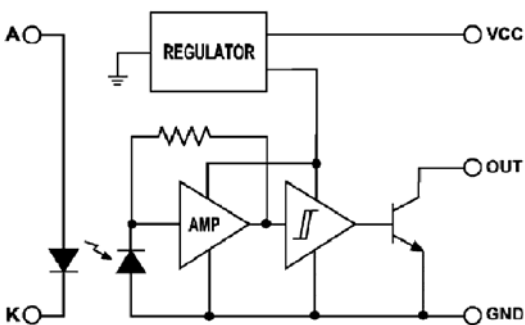

Figure 1

OUTPUT OPTIONS

The Photologic family of components is available with various output configurations (see Figure 1). The output options for the buffer designs (high logic level with light sensed and low logic level with no light sensed) and the inverter designs (low logic level with light sensed and high logic level with no light sensed). In addition there is a totem-pole output and open collector output configurations. These various output options offer the application engineer the most versatility in addressing their system needs.

TOTEM-POLE

A totem-pole configuration is very popular because of its inherent low output resistance for both a high and low output level. The low output impedance of this configuration allows a more rapid charge and discharge of any load capacitance improving its transient performance.

OPEN-COLLECTOR

With the open collector output configuration, the applications engineer can design with one or more outputs into what is referred to as collector logic or wired logic. This is simply the ability to form a logic function using the available collector outputs. In this case, the low output resistance for both the high and low output level of a totem-pole configuration is not desirable. The ability to design

OPTEK reserves the right to make changes at any time in order to improve design and to supply the best product possible.

Photologic®

with wired logic can save on the number of gates required in a system design resulting in a cost savings.

SENSITIVITY/HYSTERESIS

The Photologic family of devices operate at a spectral range of 0.15mW/cm² to 0.4mW/cm² sensitivity. This allows for the applications engineer to select from a wide range of sensitivity to fit their applications needs. A Schmitt trigger is incorporated and is very useful in transitioning a very slow rising and falling edge to a very fast rising and falling edge. An inherent characteristic of a Schmitt trigger circuit is that a different input threshold level exists for a positive and negative signal. Hysteresis is the difference between the input thresholds.

The hysteresis of the Schmitt trigger provides immunity to small input signal variations that are not desired on the output of the Photologic circuit. The larger the difference between the input thresholds, the greater the immunity to noise of signal variations. Unfortunately, the trade off is speed or output response time.

ASSEMBLIES

The combination of Photologic discrete components and the large selection of

standard housings, mechanical configurations and aperture provide the application engineer with hundreds of options to address their applications utilizing standard products. OPTEK Technology, Inc. offers the engineer a value added assembly by adding a wide variety of connectors to the standard assemblies. Contact an OPTEK Technology, Inc. sales office for price and delivery of value added assemblies.

OPTEK reserves the right to make changes at any time in order to improve design and to supply the best product possible.