

Dual Photologic®

Historically optoelectronic components such as phototransistors have been analog output devices. The application engineer had to design with an output current from the phototransistor generated by a given input bias circuit. The advent of the integrated circuits and microprocessors has required the electronics world to turn digital. The sophisticated electronics today communicate by logic levels of 1's or 0's. This means that the application engineer must now convert the analog light current of the phototransistor to a voltage level in order to communicate the sensing function to downstream processing electronics. This signal represents additional system cost in components and performance specification guard banding which can be reflected in the unit pricing of the optoelectronic component or assembly.

Dual Photologic® discrete components such as OPTEK's OPL600 family utilize the best of the analog characteristics of the optoelectronic components and the signal processing capabilities of linear integrated circuits combining the two on one chip.

DUAL PHOTOLOGIC DESCRIPTION

Dual Photologic discrete components consist of a voltage regulator, two input photodiodes, dual amplifiers with gain, two high speed comparators with hysteresis, and two power output devices. With most of the circuitry operating off an internal voltage regulator, changes due to the supply voltage are minimized. The dual Photologic sensor is used in many applications to convert input light to a logical high or low output. Its current applications include linear encoder, rotary encoder, non-contact reflective

object sensing, non-contact interruptive sensing, assembly line automation, machine safety, end of travel sensing, object sensing and paper sensing.

With the two outputs of the optoelectronic component providing the application engineer with a logical level output, processing circuitry and performance specifications are more easily designed and integrated into their application thus reducing cost and passing savings on to the customer.

OUTPUT OPTIONS

The only Dual Photologic output option currently available is for the inverter design (low logic level with light sensed and high logic level with no light sensed) with a 10k pull-up resistor (see Figure 1). Other options could be made available upon customer request. See your OPTEK sales representative for those special requirements to meet your needs.

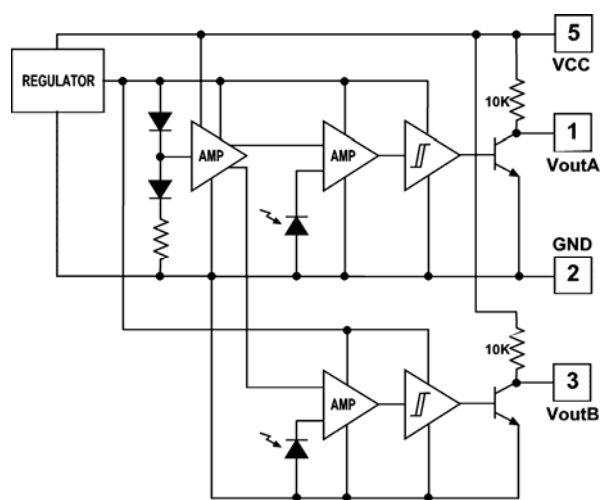

Figure 1

OPTEK reserves the right to make changes at any time in order to improve design and to supply the best product possible.

Dual Photologic®

SENSITIVITY/HYSTERESIS

The OPL622 operates typically at 0.25 mW/cm² sensitivity. A Schmitt trigger is incorporated and is very useful in transitioning a very slow rising and falling edge to a very fast rising and falling edge. An inherent characteristic of a Schmitt trigger circuit is that a different input threshold level exists for a positive and negative signal. Hysteresis is the difference between the input thresholds.

The hysteresis of the Schmitt trigger provides immunity to small input signal variations that are not desired on the output of the Photologic circuit. The larger the difference between the input thresholds, the greater the immunity to noise of signal variations. Unfortunately, the trade off is speed or output response time.

ASSEMBLIES

The Dual Photologic discrete device and the large selection of standard housings, mechanical configurations and aperture provide the application engineer with many options to address their applications utilizing standard products. OPTEK Technology, Inc. offers the engineer a value added assembly by adding a wide variety of connectors to the standard assemblies. Contact an OPTEK Technology, Inc. sales office for price and delivery of value added assemblies.

OPTEK reserves the right to make changes at any time in order to improve design and to supply the best product possible.